

SINCE 1981

# BRIGHT LED ELECTRONICS CORP.

## PHOTO LINK RECEIVER SPECIFICATION

TOTAL PAGE: 8  
 PAGE: 1  
 REVISION: 1.0

● DEVICE NUMBER : BFRX-1101/HS

SHEET DATE	1	2	3	4	5	6	7	8			CONTENTS
2003.06.05	1.0	1.0	1.0	1.0	1.0	1.0	1.0	1.0			Initial Released

TOTAL PAGE	8																			
------------	---	--	--	--	--	--	--	--	--	--	--	--	--	--	--	--	--	--	--	--

**佰鴻工業股份有限公司**  
**BRIGHT LED ELECTRONICS CORP.**

台北縣板橋市和平路 19 號 3 樓  
 3F., No. 19, Ho Ping Road, Pan Chiao City,  
 Taipei, Taiwan, R. O. C.  
 Tel: 886-2-29591090  
 Fax: 886-2-29547006/29558809  
[www.brtled.com](http://www.brtled.com)

APPROVED	DRAWN

# BRIGHT LED ELECTRONICS CORP.

## PHOTO LINK RECEIVER SPECIFICATION

● DEVICE NUMBER: BFRX-1101/HS

PAGE: 2

REVISION: 1.0

● **Features:**

1. Conform to EIAJ Standard CP-1201 (For Digital Audio Interface including Fiber Optic inter-connections).
2. ATC (Automatic Threshold Control) Circuit is used for stabilized output at a wide range of optical power level.
3. A self-tapping hole for easy attachment to the panel of Audio Equipments.
4. Operating voltage: 4.75 to 5.25 V.
5. Compatible Toshiba Toslink mini-package type.

● **Outline Dimensions**

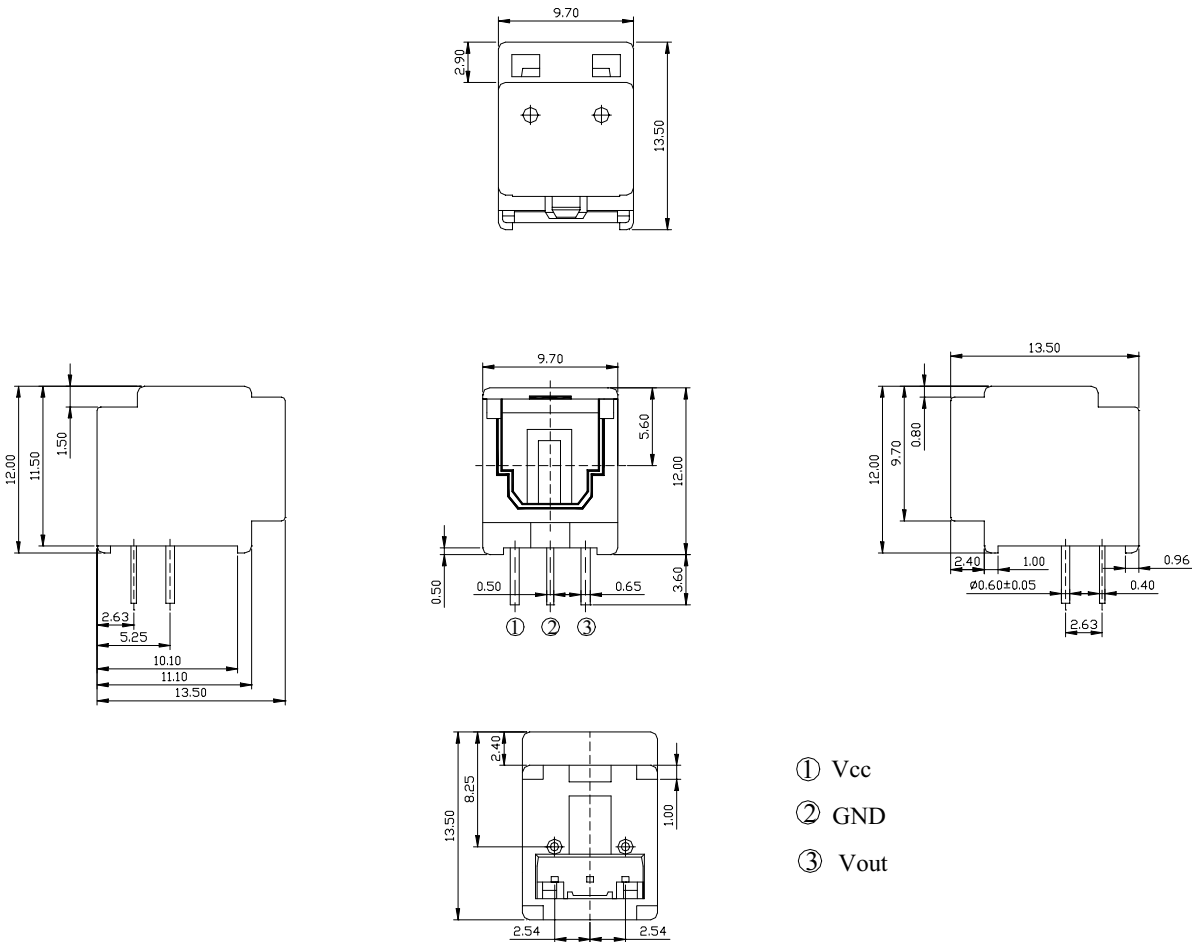

● **Recommended drilling as viewed from the soldering face**

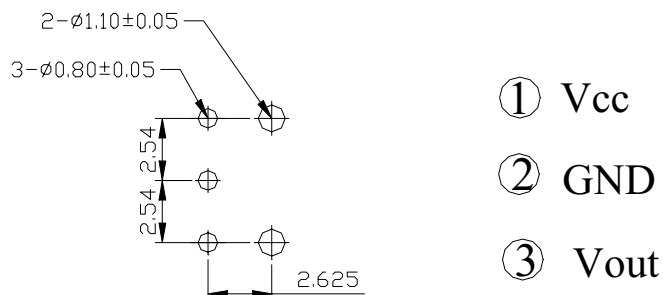

NOTES: Tolerance is  $\pm 0.3$  mm unless otherwise noted.

# BRIGHT LED ELECTRONICS CORP.

## PHOTO LINK RECEIVER SPECIFICATION

●DEVICE NUMBER : BFRX-1101/HS

PAGE: 3

REVISION: 1.0

### ●Absolute Maximum Ratings (Ta=25°C)

Parameter	Symbol	Rating	Unit
Storage Temperature	Tstg	-40 to + 70	°C
Operating Temperature	Topr	-20 to + 70	°C
Supply Voltage	Vcc	-0.5 to + 7	V
Low level Output Current	I <sub>OL</sub>	5	mA
High level Output Current	I <sub>OH</sub>	-1	mA
Soldering Temperature	Tsol	260 <sup>(1)</sup>	°C

Note <sup>(1)</sup> Soldering time ≤ 5 seconds (More than 1mm apart from package).

### ●Electro-Optical Characteristics (Ta=25°C)

Parameter	Symbol	Conditions	MIN.	TYP.	MAX.	Unit
Peak wavelength	$\lambda_p$		---	660	---	nm
Operating supply voltage	Vcc		4.75	5.0	5.25	V
Data rate	T	NRZ code	0.1	---	6.0	Mbps
Transmission Distance	D	Using APF (All Plastic Fiber, 970/1000 $\mu$ m) and BFTX-1001	0.2	---	5	m
Maximum Receivable Power	P <sub>MAX</sub>	6Mbps, Using APF	-14.5	---	---	dBm
Minimum Receivable Power	P <sub>MIN</sub>	6Mbps, Using APF	---	---	-24	dBm
Dissipation current	I <sub>cc</sub>	Refer to Fig. 1	---	22	40	mA
High level output voltage	V <sub>oH</sub>	Refer to Fig. 2	3.6	4.0	---	V
Low level output voltage	V <sub>oL</sub>	Refer to Fig. 2	---	0.2	0.4	
Rise time	t <sub>r</sub>	Refer to Fig. 2	---	20	40	ns
Fall time	t <sub>f</sub>	Refer to Fig. 2	---	20	40	ns
Low→High delay time	t <sub>PLH</sub>	Refer to Fig. 2	---	---	180	ns
High→Low delay time	t <sub>PHL</sub>	Refer to Fig. 2	---	---	180	
Pulse width distortion	$\Delta$ tw	Refer to Fig. 2	-30	---	+30	
Jitter	$\Delta$ tj	Refer to Fig. 2	---	---	30	

### ●Mechanical Characteristics (Ta=25°C)

Parameter	Symbol	Conditions	MIN.	TYP.	MAX.	Unit
Insertion Force		* 1	---	---	40	N
Withdrawal Force		* 1	6	---	40	
Torque for Self-Tap		Using self-tapping screw (M3 x 8)	60	---	100	N-cm

\* 1 : Using standard optical fiber cable ( 970/1000  $\mu$ m)

# BRIGHT LED ELECTRONICS CORP.

## PHOTO LINK RECEIVER SPECIFICATION

● DEVICE NUMBER: BFRX-1101/HS

PAGE: 4

REVISION: 1.0

● Fig.1 Measuring Method of Dissipation Current.

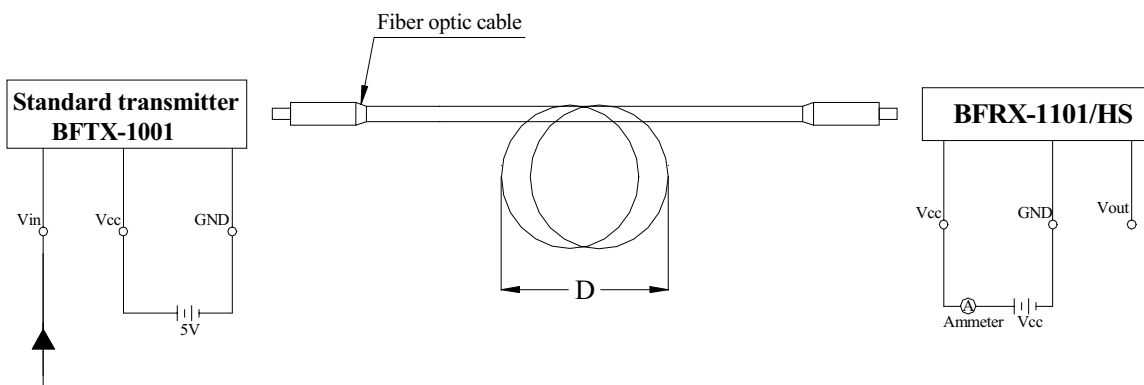

Input



6Mbps NRZ, Duty 50%

- Notes:
- (1)  $V_{cc}=5.0V$  (State of operating)
  - (2) To bundle up the standard fiber optic cable, make it into a loop with the diameter  $D=10cm$  or more.
  - (3)  $P_c=-14.5dBm$
  - (4) Measured on an ammeter

# BRIGHT LED ELECTRONICS CORP.

## PHOTO LINK RECEIVER SPECIFICATION

● DEVICE NUMBER: BFRX-1101/HS

PAGE: 5

REVISION: 1.0

● Fig.2 Measuring Method of Output Voltage and Pulse Response.

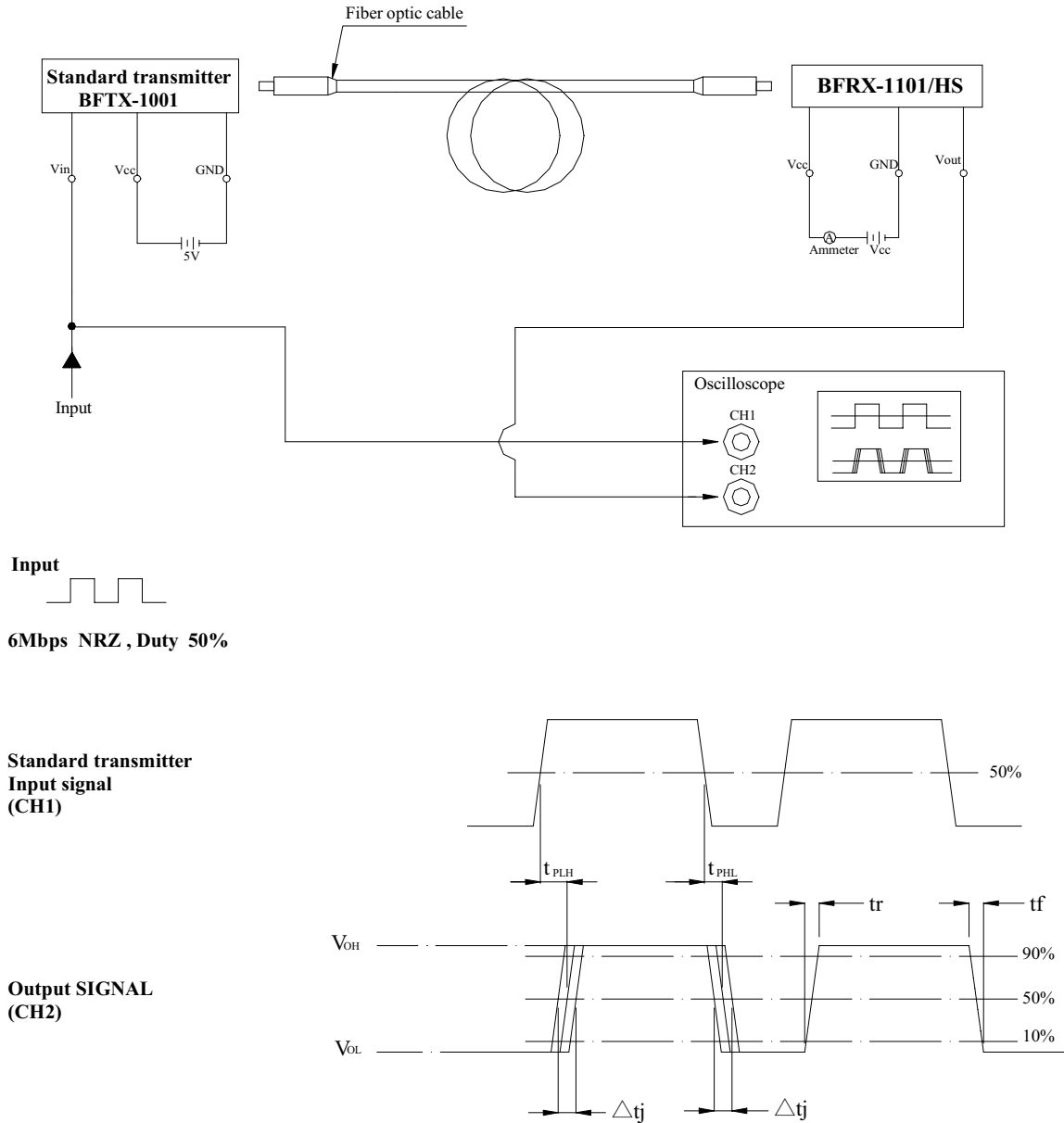

Test item

Test item	Symbol	Test item
Low→High pulse delay time	$t_{PLH}$	Refer to the above prescriptions.
High→Low pulse delay time	$t_{PHL}$	Refer to the above prescriptions.
Rise time	$t_r$	Refer to the above prescriptions.
Fall time	$t_f$	Refer to the above prescriptions.
High level output voltage	$V_{OH}$	Refer to the above prescriptions.
Low level output voltage	$V_{OL}$	Refer to the above prescriptions.
Pulse width distortion	$\Delta tw$	$\Delta tw = t_{PHL} - t_{PLH}$ .
Jitter	$\Delta t_j$	Set the trigger on the rise of input signal to measure the jitter of the rise of output

# BRIGHT LED ELECTRONICS CORP.

## PHOTO LINK RECEIVER SPECIFICATION

● DEVICE NUMBER: BFRX-1101/HS

PAGE: 6

REVISION: 1.0

### ● System Configuration Example:

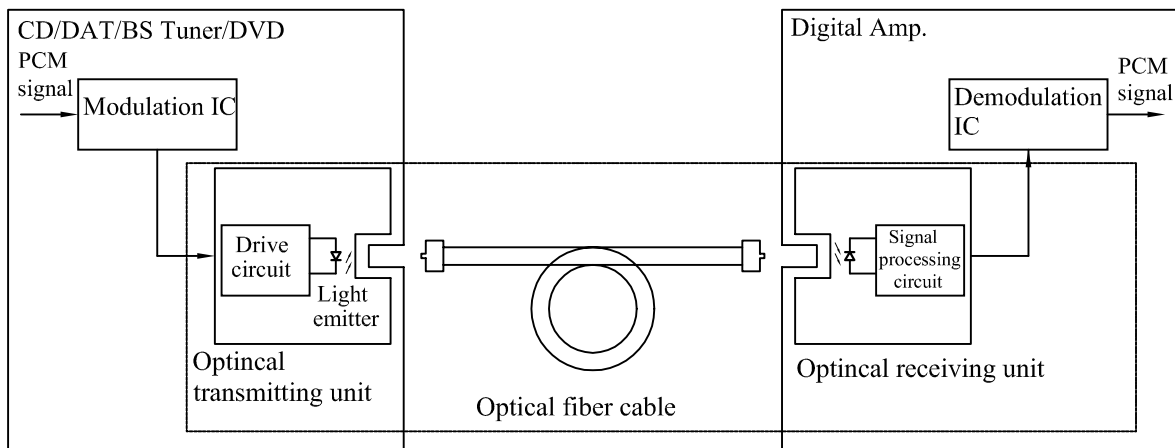

### ● Recommended Connection Method:

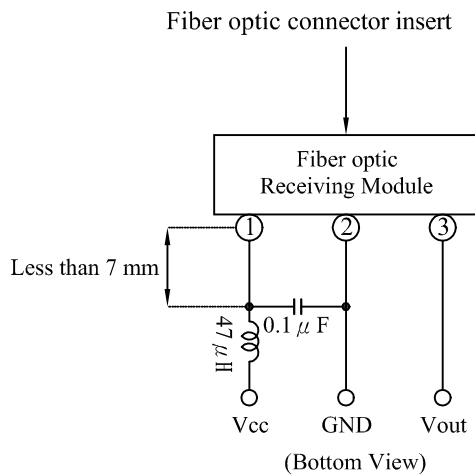

# BRIGHT LED ELECTRONICS CORP.

## PHOTO LINK RECEIVER SPECIFICATION

### RELIABILITY TEST

PAGE: 7

REVISION: 1.0

Classification	Test Item	Reference Standard	Test Conditions	Result
Endurance Test	Operation Life	MIL-STD-750:1026 MIL-STD-883:1005 JIS C 7021 :B-1	Connect with a power $V_{cc}=5V$ $T_a$ =Under room temperature Test time=1,000hrs	0/20
	High Temperature High Humidity Storage	MIL-STD-202:103B JIS C 7021 :B-11	$T_a=85^{\circ}C \pm 5^{\circ}C$ RH=90%-95% Test time=240hrs	0/20
	High Temperature Storage	MIL-STD-883:1008 JIS C 7021 :B-10	High $T_a=105^{\circ}C \pm 5^{\circ}C$ Test time=1,000hrs	0/20
	Low Temperature Storage	JIS-C-7021 :B-12	Low $T_a=-55^{\circ}C \pm 5^{\circ}C$ Test time=1,000hrs	0/20
Environmental Test	Temperature Cycling	MIL-STD-202:107D MIL-STD-750:1051 MIL-STD-883:1010 JIS C 7021 :A-4	$-55^{\circ}C \sim 25^{\circ}C \sim 105^{\circ}C \sim 25^{\circ}C$ 30min 5min 30min 5min Test Time=10cycle	0/20
	Thermal Shock	MIL-STD-202:107D MIL-STD-750:1051 MIL-STD-883:1011	$-55^{\circ}C \pm 5^{\circ}C \sim 105^{\circ}C \pm 5^{\circ}C$ 10min 10min Test Time=10cycle	0/20
	Solder Resistance	MIL-STD-202:201A MIL-STD-750:2031 JIS C 7021 :A-1	$T_{sol}=260 \pm 5^{\circ}C$ Dwell Time=5±1sec.	0/20
	Solder ability	MIL-STD-202:208D MIL-STD-750:2026 MIL-STD-883:2003 JIS C 7021 :A-2	$T_{sol}=230 \pm 5^{\circ}C$ Dwell Time=5±1sec.	0/20
	Lead Bending Stress	MIL-STD-750:2036 JIS C 7021 :A-11	$0^{\circ} \sim 90^{\circ} \sim 0^{\circ}$ bend , 3 cycles Weight 250g	0/20

### JUDGMENT CRITERIA OF FAILURE FOR THE RELIABILITY

Parameter	Symbol	Measuring conditions	Judgement criteria for failure
Receivable power	$P_c$	$V_{cc}=5V$	-14.5dBm~24dBm
Dissipation current	$I_{cc}$	$V_{cc}=5V$	Over $U \times 2$

Note: 1.U means the upper limit of specified characteristics.

2.Measurment shall be taken between 2 hours and after the test pieces have been returned to normal ambient conditions after completion of each test.

# BRIGHT LED ELECTRONICS CORP.

## PHOTO LINK RECEIVER SPECIFICATION

### PACKAGING DIMMENSIONS

● DEVICE NUMBER: BFRX-1101/HS

PAGE: 8

● Package Method:(unit:mm)

REVISION: 1.0

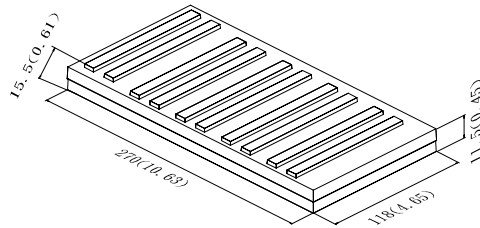
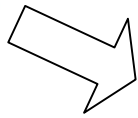

Tray

100 Pcs / Tray

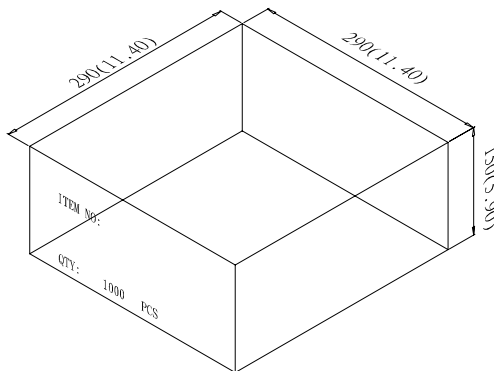

Inner box

10 Tray / Inner box

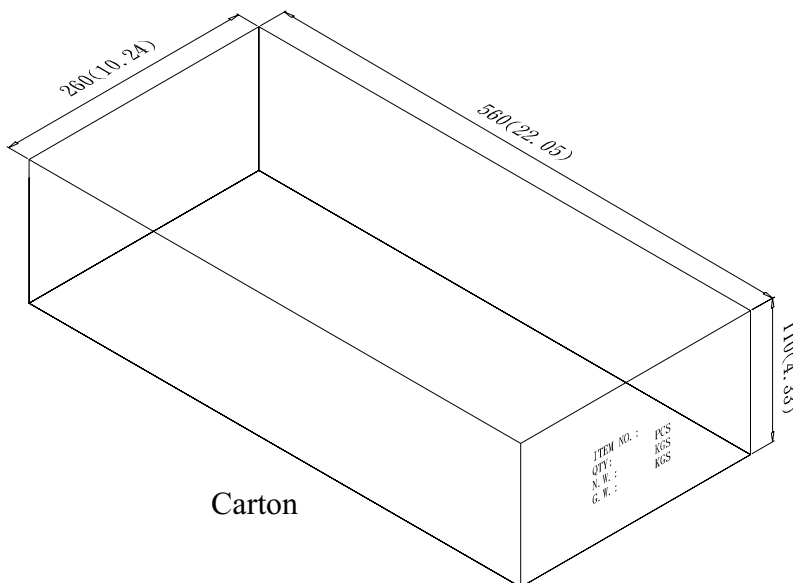

Carton

2 Inner box / Carton

NOTES : Tray : Tolerance is  $\pm 5$  mm unless otherwise noted.

Inner box : Tolerance is  $\pm 10$  mm unless otherwise noted.

Carton : Tolerance is  $\pm 10$  mm unless otherwise noted.