

BRIGHT LED ELECTRONICS CORP.

PHOTO LINK TRANSMITTER SPECIFICATION

● DEVICE NUMBER: BFTX-1001/H5

PAGE: 2

REVISION: 1.0

● Features:

1. Uni-directional data transmission using plastic fiber.
2. Operating voltage: 4.75 to 5.25 V.
3. TTL and high speed C-MOS LOGIC compatible.
4. Compatible sharp opto link with shutter type.

● Outline Dimensions

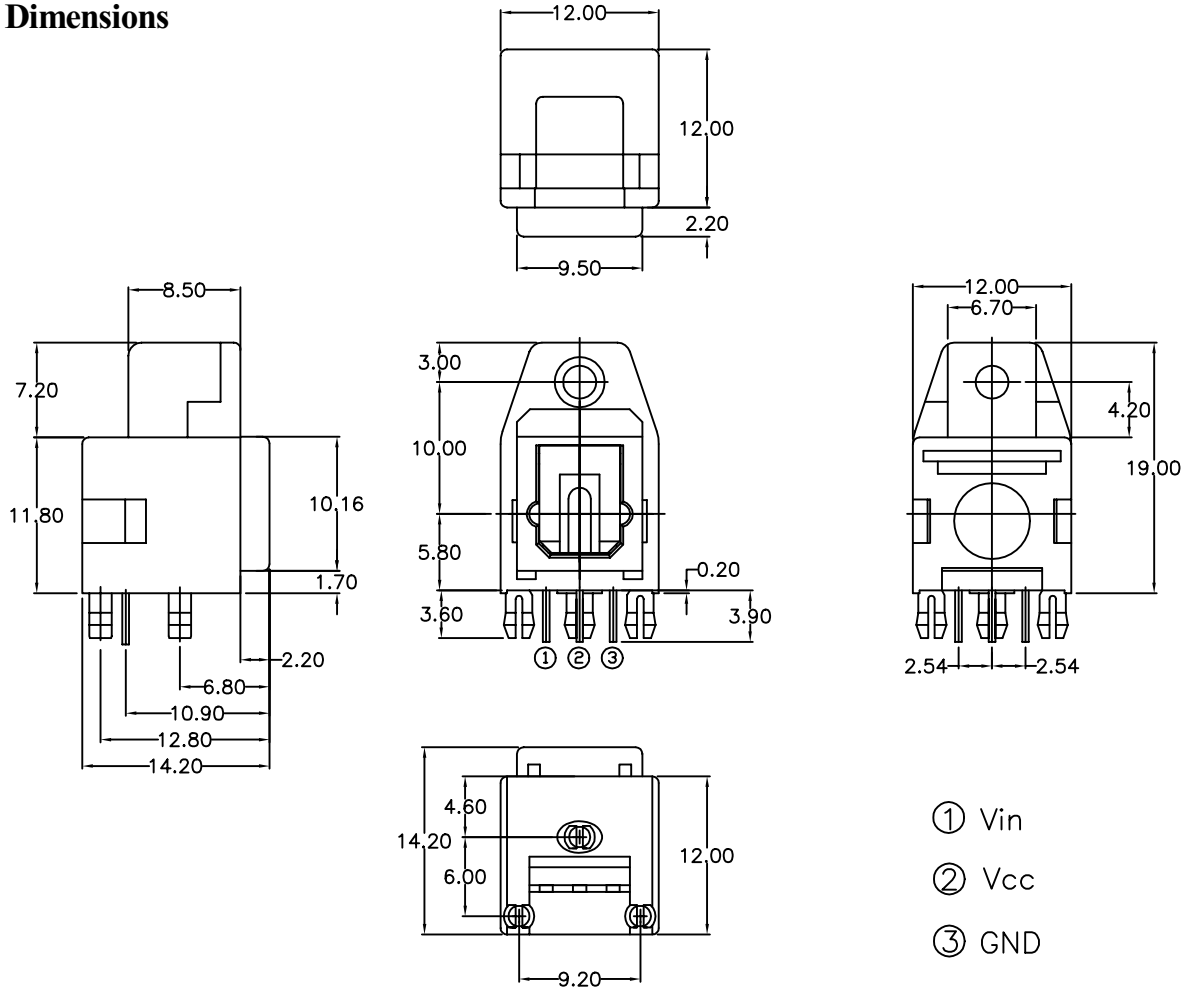

● Recommended drilling as viewed from the soldering face

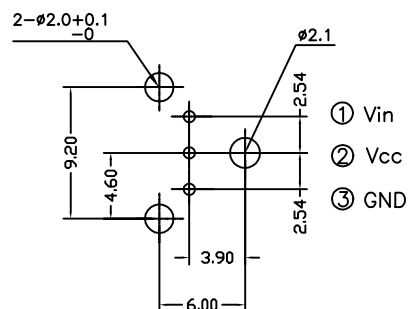

NOTES: Tolerance is ± 0.3 mm unless otherwise noted.

BRIGHT LED ELECTRONICS CORP.

PHOTO LINK TRANSMITTER SPECIFICATION

●DEVICE NUMBER : BFTX-1001/H5

PAGE: 3

REVISION: 1.0

●Absolute Maximum Ratings (Ta=25°C)

Parameter	Symbol	Rating	Unit
Power Dissipation	Pd	100	mw
Supply voltage	Vcc	-0.5 to + 7	V
Input voltage	Vin	-0.5 to Vcc + 0.5	
Operating temperature	Topr	-20 to + 70	°C
Storage temperature	Tstg	-30 to + 80	
Soldering temperature	Tsol	260 For 5sec	

●Electro-Optical Characteristics (Ta=25°C)

Parameter	Symbol	Conditions	MIN.	TYP.	MAX.	Unit
Peak wavelength	λ_p		---	660	---	nm
Operating supply voltage	Vcc		4.75	5.0	5.25	V
Data rate	T	NRZ code	---	---	12.0	Mbps
Transmission Distance	D	Using All Plastic Fiber (970/1000 μ m) and TORX179	0.2	---	5	m
Optical power output	Pc	Refer to Fig. 1	-21	-17	-15	dBm
Dissipation current	Icc	Refer to Fig. 2	---	8	13	mA
High level input voltage	V _{iH}	Refer to Fig. 2	1.5	---	Vcc	V
Low level input voltage	V _{iL}	Refer to Fig. 2	0	---	0.8	
Low→High delay time	t _{PLH}	Refer to Fig. 3	---	---	180	ns
High→Low delay time	t _{PHL}	Refer to Fig. 3	---	---	180	
Pulse width distortion	Δ tw	Refer to Fig. 3	-25	---	+25	
Jitter	Δ tjr	Refer to Fig. 3	---	4	25	

●Mechanical Characteristics (Ta=25°C)

Parameter	Symbol	Conditions	MIN.	TYP.	MAX.	Unit
Insertion Force		* 1	---	---	40	N
Withdrawal Force		* 1	6	---	40	
Torque for Self-Tap		Using self-tapping screw (M3 x 8)	60	---	100	N-cm

* 1 : Using standard optical fiber cable (970/1000 μ m)

BRIGHT LED ELECTRONICS CORP.

PHOTO LINK TRANSMITTER SPECIFICATION

●DEVICE NUMBER: BFTX-1001/H5

PAGE: 4

REVISION: 1.0

●Fig.1 Measuring Method of Optical Output Coupling with Fiber.

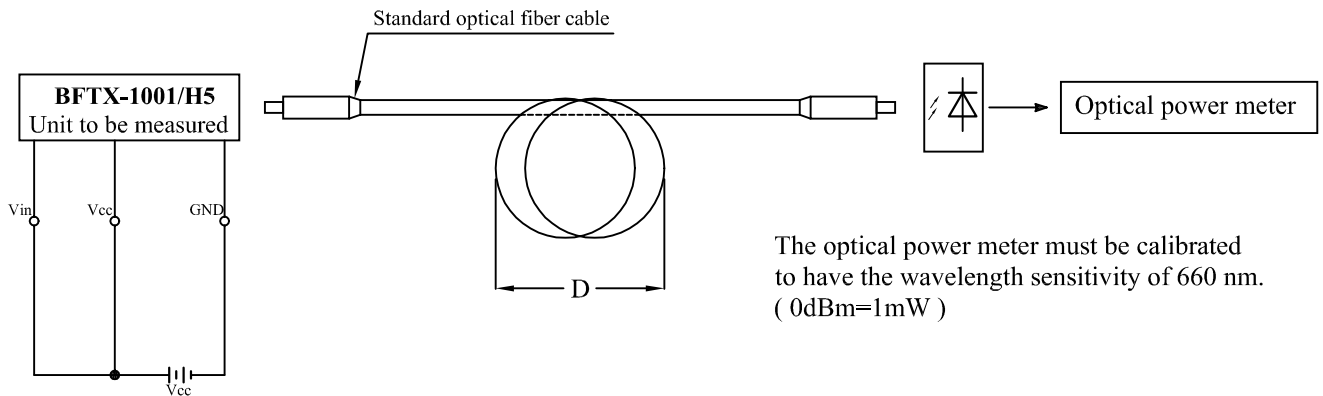

- Notes: (1) $V_{cc}=5.0V$ (State of operating)
 (2) To bundle up the standard fiber optic cable, make it into a loop with the diameter $D=10cm$ or more.

●Fig.2 Measuring Method of Input Voltage and Supply Current.

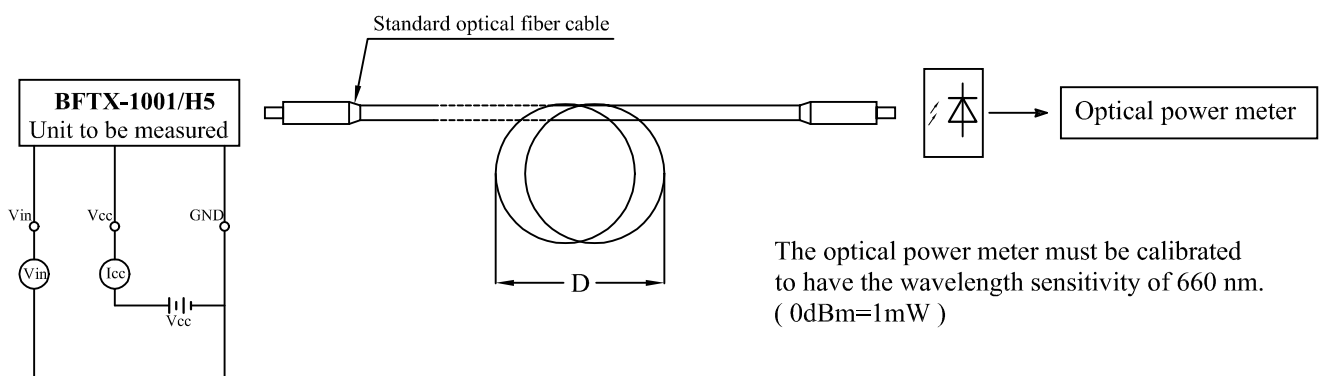

Input conditions and judgment method Supply Current.

Conditions	Judgment method
$V_{in}=2.1V$ or more	$-21 \text{ dBm} \leq P_c \leq -15 \text{ dBm}$, $I_{cc}=13mA$ or less
$V_{in}=0.8 V$ or less	$P_c \leq -36 \text{ dBm}$, $I_{cc}=13mA$ or less

Notes: $V_{cc}=5.0V$ (State of operating).

BRIGHT LED ELECTRONICS CORP.

PHOTO LINK TRANSMITTER SPECIFICATION

● DEVICE NUMBER: BFTX-1001/H5

PAGE: 5

REVISION: 1.0

● Fig.3 Measuring Method of Pulse Response and Jitter.

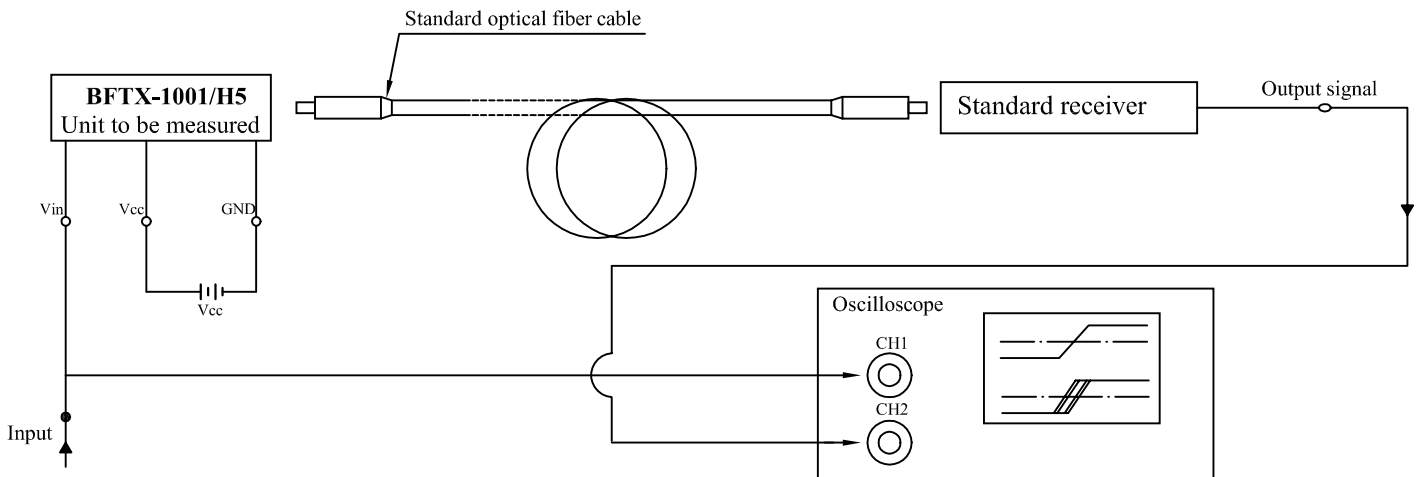

12Mbps NRZ code, duty 50%

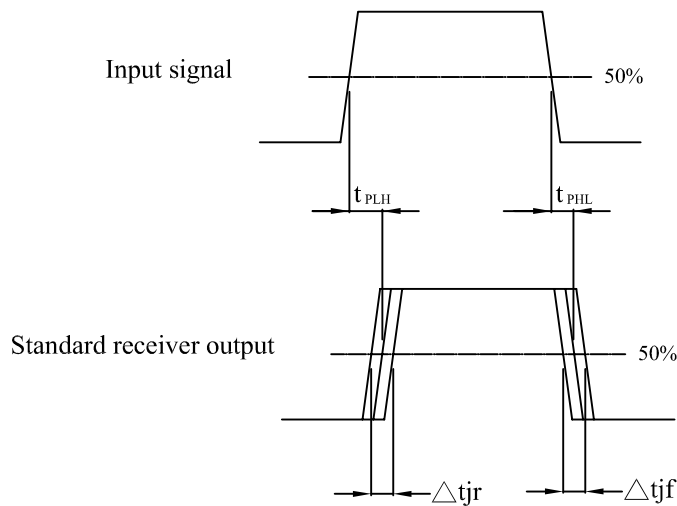

Test item

Test item	Symbol	Test item
Low→High pulse delay time	t_{PLH}	Refer to the above prescriptions.
High→Low pulse delay time	t_{PHL}	Refer to the above prescriptions.
Pulse width distortion	Δtw	$\Delta tw = t_{PHL} - t_{PLH}$
Low→High Jitter	Δt_{jr}	Set the trigger on the rise of input signal to measure the jitter of the rise of output.
High→Low Jitter	Δt_{jf}	Set the trigger on the fall of input signal to measure the jitter of the fall of output.

- Notes:
- (1) The waveform write time shall be 4 seconds. But do not allow the waveform to be distorted by increasing the brightness too much.
 - (2) $V_{cc} = 5.0V$ (State of operating)
 - (3) To probe for the oscilloscope must be more than $1M\Omega$ and less than $10pF$.

BRIGHT LED ELECTRONICS CORP.

PHOTO LINK TRANSMITTER SPECIFICATION

● DEVICE NUMBER: BFTX-1001/H5

PAGE: 6

REVISION: 1.0

● System Configuration Example:

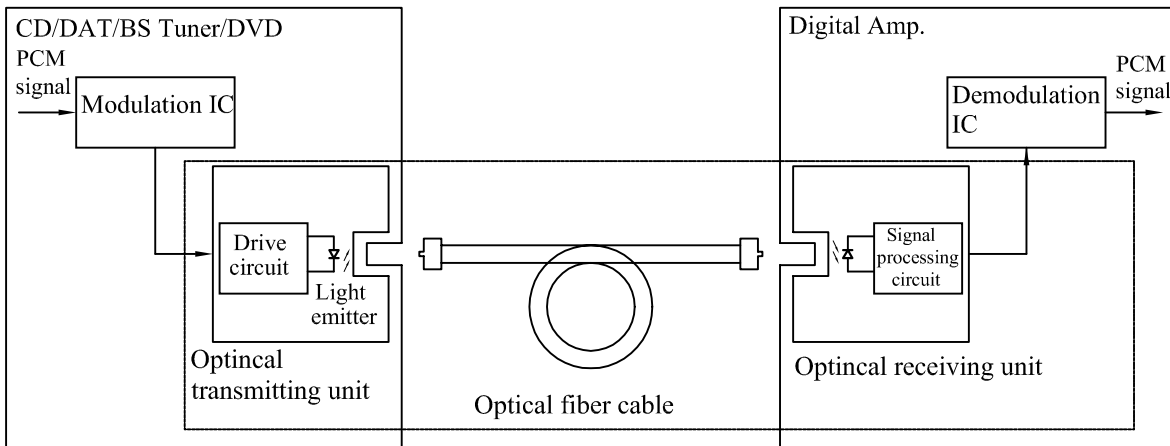

● Application Circuit:

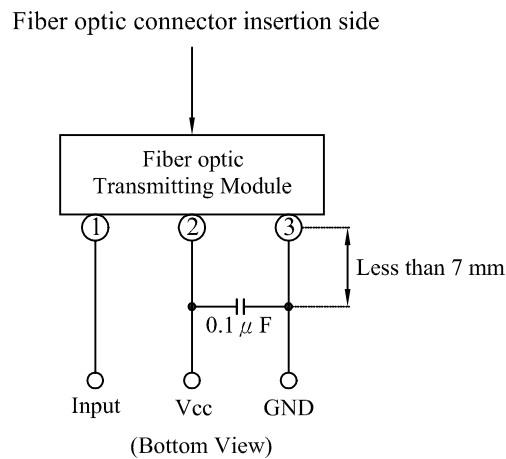

BRIGHT LED ELECTRONICS CORP.

PHOTO LINK TRANSMITTER SPECIFICATION

RELIABILITY TEST

PAGE: 7

REVISION: 1.0

Classification	Test Item	Reference Standard	Test Conditions	Result
Endurance Test	Operation Life	MIL-STD-750:1026 MIL-STD-883:1005 JIS C 7021 :B-1	Connect with a power $V_{cc}, V_{in}=5V$ T_a =Under room temperature Test time=1,000hrs	0/20
	High Temperature High Humidity Storage	MIL-STD-202:103B JIS C 7021 :B-11	$T_a=85^{\circ}C \pm 5^{\circ}C$ RH=90%-95% Test time=240hrs	0/20
	High Temperature Storage	MIL-STD-883:1008 JIS C 7021 :B-10	High $T_a=105^{\circ}C \pm 5^{\circ}C$ Test time=1,000hrs	0/20
	Low Temperature Storage	JIS-C-7021 :B-12	Low $T_a=-55^{\circ}C \pm 5^{\circ}C$ Test time=1,000hrs	0/20
Environmental Test	Temperature Cycling	MIL-STD-202:107D MIL-STD-750:1051 MIL-STD-883:1010 JIS C 7021 :A-4	$-55^{\circ}C \sim 25^{\circ}C \sim 105^{\circ}C \sim 25^{\circ}C$ 30min 5min 30min 5min Test Time=10cycle	0/20
	Thermal Shock	MIL-STD-202:107D MIL-STD-750:1051 MIL-STD-883:1011	$-55^{\circ}C \pm 5^{\circ}C \sim 105^{\circ}C \pm 5^{\circ}C$ 10min 10min Test Time=10cycle	0/20
	Solder Resistance	MIL-STD-202:201A MIL-STD-750:2031 JIS C 7021 :A-1	$T_{sol}=260 \pm 5^{\circ}C$ Dwell Time= 5 ± 1 sec.	0/20
	Solder ability	MIL-STD-202:208D MIL-STD-750:2026 MIL-STD-883:2003 JIS C 7021 :A-2	$T_{sol}=230 \pm 5^{\circ}C$ Dwell Time= 5 ± 1 sec.	0/20
	Lead Bending Stress	MIL-STD-750:2036 JIS C 7021 :A-11	$0^{\circ} \sim 90^{\circ} \sim 0^{\circ}$ bend , 3 cycles Weight 250g	0/20

JUDGMENT CRITERIA OF FAILURE FOR THE RELIABILITY

Parameter	Symbol	Measuring conditions	Judgement criteria for failure
Optical power output	P_c	$V_{cc}, V_{in}=5V$	-21dBm~-15dBm
Dissipation current	I_{cc}	$V_{cc}, V_{in}=5V$	Over U_{x2}

Note: 1.U means the upper limit of specified characteristics. S means initial value.

2.Measurment shall be taken between 2 hours and after the test pieces have been returned to normal ambient conditions after completion of each test.

BRIGHT LED ELECTRONICS CORP.

PHOTO LINK TRANSMITTER SPECIFICATION

PACKAGING DIMMENSIONS

● DEVICE NUMBER: BFTX-1001/H5

PAGE: 8

REVISION: 1.0

● Package Method:(unit:mm)

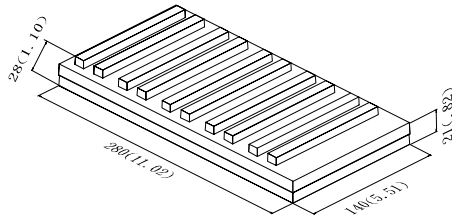
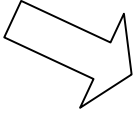
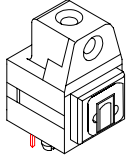

100 Pcs / Tray

Tray

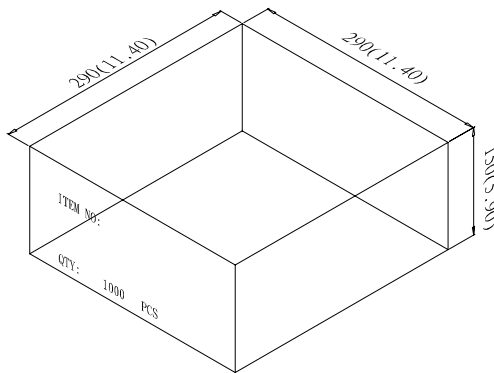
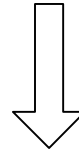

10 Tray / Inner box

Inner box

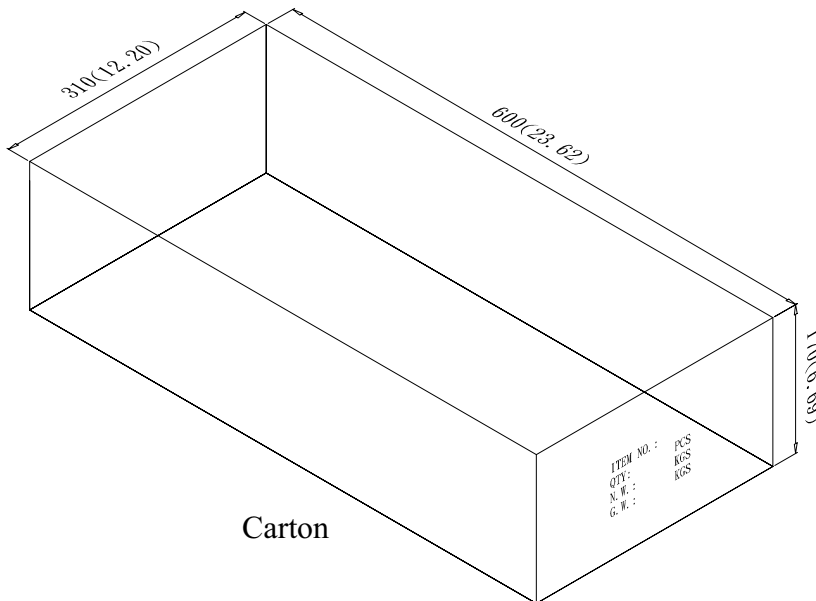
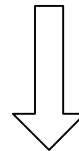

2 Inner box / Carton

Carton

NOTES : Tray : Tolerance is ± 5 mm unless otherwise noted.

Inner box : Tolerance is ± 10 mm unless otherwise noted.

Carton : Tolerance is ± 10 mm unless otherwise noted.